

951D SERIES 12mm dia. SPUR SUB MINIATURE GEARED MOTOR

(951D MOTOR)



IMPORTANT NOTICE
Due to the wide range of applications for this product it is the users responsibility to establish the products suitability for their individual purpose(s).

RATIOS NOW AVAILABLE AS EX-STOCK ITEMS.

951D101 (1.5v - 3v)	WITH 951D MOTOR.	RATIO 10:1
951D601 (1.5v - 3v)	WITH 951D MOTOR.	RATIO 60:1
951D1021 (1.5v - 3v)	WITH 951D MOTOR	RATIO 102:1
951D2981 (1.5v - 3v)	WITH 951D MOTOR.	RATIO 298:1

All metal spur geared motor for sub miniature applications. The combination of a high quality three pole motor with precious metal brushes, mounted onto a rugged all metal gearbox ensure a reliable service life.

MOTOR DATA. (RE-951D)

MODEL	VOLTAGE		NO LOAD		AT MAXIMUM EFFICIENCY						STALL TORQUE	
	OPERATING RANGE	NOMINAL	SPEED	CURRENT	SPEED	CURRENT	TORQUE		OUTPUT	EFF	oz - in	g - cm
			R.P.M.	A	R.P.M.	A	oz - in	g - cm	W	%	EST 20	
951D	1.5 - 3.0	3v CONSTANT	16000	0.1	13500	0.32		3.9	0.58	60		

REDUCTION TABLE. R.P.M.

SUPPLY VOLTAGE	1.5v	3.0v
951D101	685	1450
951D601	120	250
951D1021	67	144
951D2981	25	52

WEIGHT	
951D101	10g
951D601	10g
951D1021	10g
951D2981	10g

Note: Motor speeds may vary by (+) or (-) 12.5%

GEARBOX RATINGS

RATED TOLERANCE TORQUE (g.cm)	MAX MOMENTARY TOLERANCE TORQUE	EFFICIENCY %
10:1	300	81
60:1	600	66
102:1		
298:1	1000	59

NOTE: To establish Torque Rating in Nm, divide g.cm by 10,197.0

IMPORTANT NOTICE
At very low ratios the torque produced by this geared motor combination may exceed the maximum permissible torque of the gearbox. In this situation the unit must not be allowed to stall as this may damage the gears. Please refer to the table of the gearbox ratings to ascertain the appropriate geared motor combination.

951D SERIES 12mm dia. SPUR SUB MINIATURE GEARED MOTOR

GEARBOX DIMENSIONS

GEARBOX REF.	A (mm)
951D10:1 (10:1)	9.15
951D60:1 (60:1)	9.15
951D102:1 (102:1)	9.15
951D298:1 (298:1)	9.15

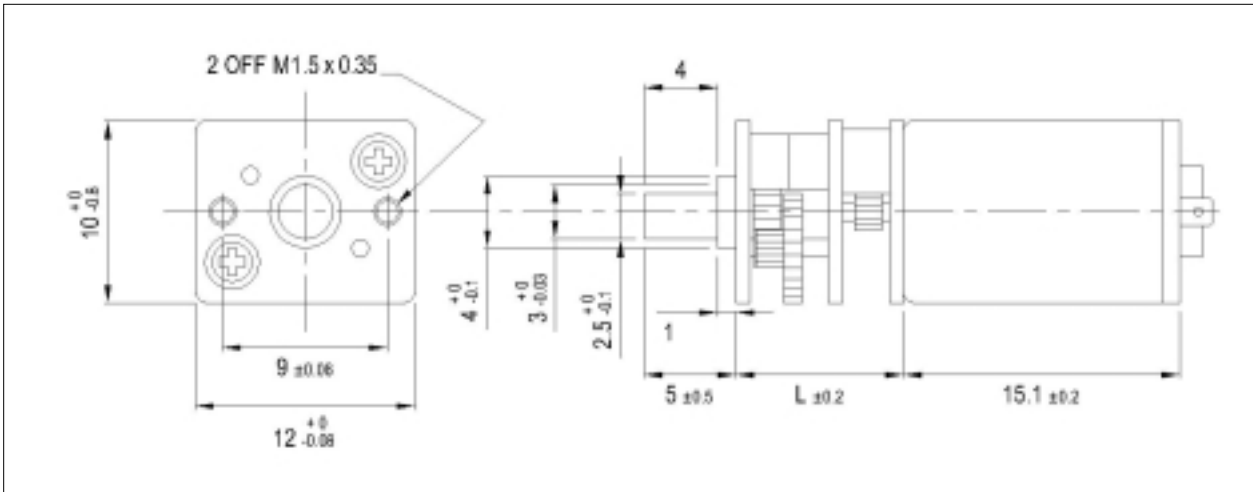

FOR ACCESSORIES TO FIT THIS SERIES GEARBOX, REFER TO 918D SERIES PAGE.

Subject to minimum order quantities of 250 units, the following ratios are also available with a six week lead-time. The physical dimensions of these other gearboxes may vary from the data as illustrated above. Details of individual gearboxes are available upon request.

- 19:1 29:1
- 76:1 102:1
- 134:1 197:1
- 235:1